

## Catawba Sunrise Features...

### Floors

2 x 10 Floor Joist, 16" on Center  
 ¾" OSB Tongue and Groove Subfloor

### Exterior Walls

2 x 6 Exterior Walls, 16" on Center  
 3/8" Sub-Siding on Full Perimeter of Each Module  
 DuPont Tyvek® House Wrap  
 Vinyl Siding and Accessories  
 Andersen 200 Series Double Hung Tilt Windows  
 with Low E Insulating Glass  
 Andersen Gliding Door with Low E Insulating Glass  
 Metal Clad Insulated Exterior Doors

### Roof

8/12 Pitch Roof Truss System, 24" on Center  
 7/16" OSB Roof Sheathing  
 Shingle Underlayment Felt Paper  
 CertainTeed Landmark Roof Shingles (30 Year)

### Insulation

R-38 Ceiling Insulation - 12" Fiberglass Batt  
 R-19 Insulation in Exterior Walls - 6" Fiberglass Batt  
 R-10 Foundation Insulation

### Heating

90% Efficient Forced Air Gas Furnace  
 Air Conditioning, 12 SEER Unit

### Garage

Storage Trusses  
 Drywall on Adjoining House Wall, Joints Taped  
 Drywall on Ceiling, Joints Taped  
 Two GFI Outlets  
 Insulated Steel Overhead Garage Doors  
 Overhead Garage Door Openers



*Elevation A*



*Elevation B*

### Interior

9' Ceiling Height  
 2 x 4 Interior Walls, 24" on Center  
 2 x 3 Center Marriage Wall, 16" on Center, on  
 Each Side  
 ½" Finished Drywall with Smooth Finish on Walls  
 ½" Drywall with Textured Finish on Ceilings  
 All Interior Drywall Surfaces are Finished with  
 White Latex Paint  
 Painted Masonite Six Panel Interior Doors  
 Painted 3½" FJ White Pine Casing  
 Painted 5 ¼" FJ White Pine Base Trim  
 Ventilated Shelving in Closets  
 Floor Covering Allowance Per Plan

### Kitchen Features

HAAS Oak Kitchen Cabinets  
 Laminate Counter Top  
 8" Deep Stainless Steel Sink  
 Kohler Single Lever Faucet with Spray  
 Disposal

### Bath Features

HAAS Oak Bathroom Vanities  
 Laminated Counter Top with Ceramic Bowl  
 Medicine Cabinet or Mirror (Per Plan)  
 Kohler Fiberglass Tub and/or Shower Units  
 Kohler Single Lever Faucets

### Plumbing

Copper Water Lines  
 PVC Waste Lines  
 Frost Proof Outside Water Faucets (2)  
 50 Gallon Water Heater

### Electric

All Electric Work in Accordance with the  
 National Electric Code  
 200 AMP Electric Circuit Breaker Service  
 Smoke Alarms Per Code  
 Interior & Exterior Lights Per Plan  
 Exterior Waterproof Outlets Per Plan (2)  
 Pre-Wired for Cable TV and Phone Per Plan

### Miscellaneous

Dedicated Streets, Built to County Specifications  
 Public Sewer and Water Services  
 Underground Utilities - Electric, Gas, Phone & Cable  
 18' Wide Concrete Driveway  
 4' Wide Concrete Front Door Walkway  
 Front Yard Post Lamp  
 Mail Box  
 Professional Landscaping Package

Artist's renderings and floor plan dimensions are  
 approximate. All specifications must be written in  
 the contract. No Verbal Agreements.

*Catawba Bay*

"Affordable living on the Water"



*The Catawba Sunrise Elevation C*

## The Catawba Sunrise

Homes By Catawba Bay Builders, LLC  
 Home Sites by Lost Lake Development, LLC  
 5050 E. Muggy Rd., Port Clinton  
 419-797-2100  
[www.catawbabay.info](http://www.catawbabay.info)

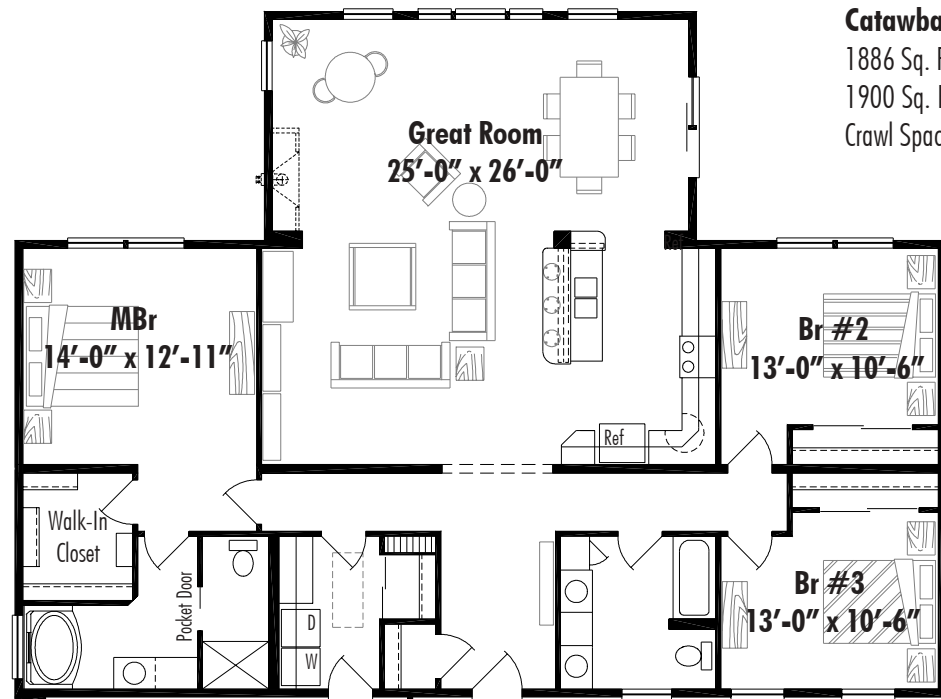

**Catawba Sunrise\***  
 1886 Sq. Ft. Living Area (Elev. A)  
 1900 Sq. Ft. Living Area (Elev. B & C)  
 Crawl Space Plan

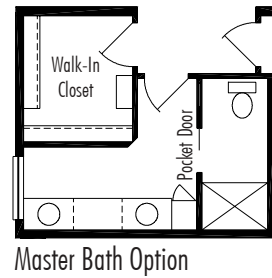

Windows for Elevation B & C\*\*

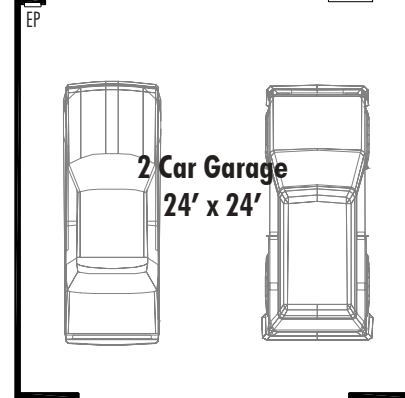

Elevation A



Elevation B



Elevation C

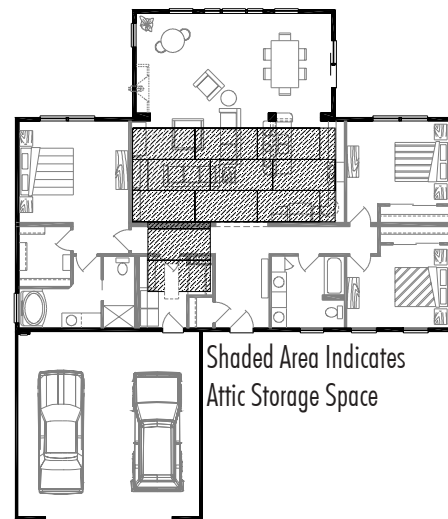

Shaded Area Indicates  
 Attic Storage Space

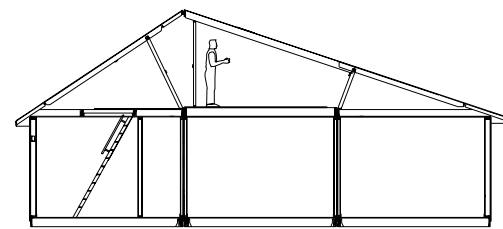

Attic Storage Area on Sunrise Crawl and Basement Plans

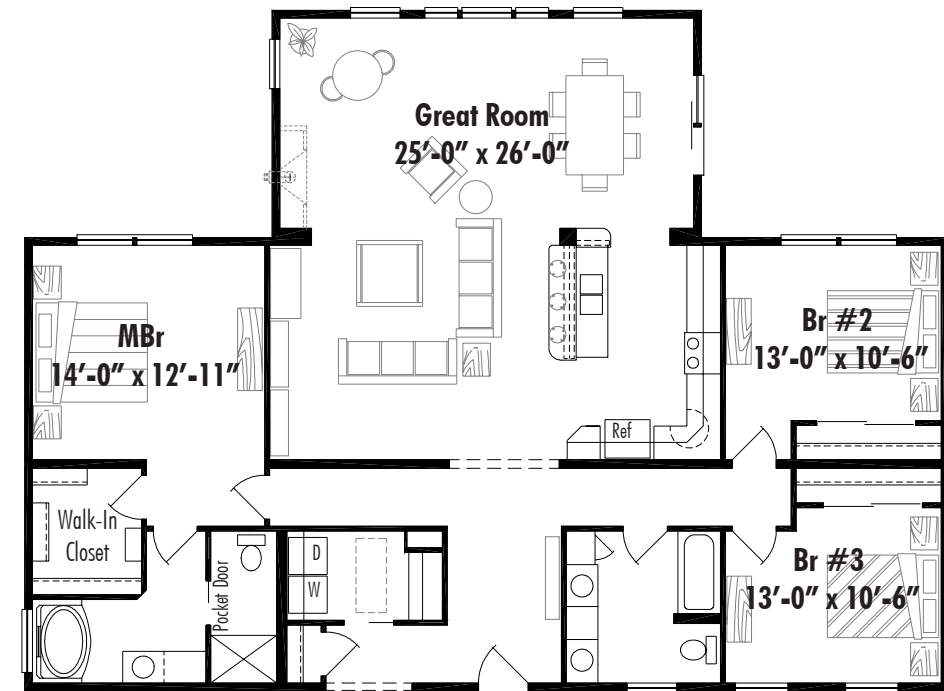

**Catawba Sunrise\***  
 1886 Sq. Ft. Living Area (Elev. A)  
 1900 Sq. Ft. Living Area (Elev. B & C)  
 Basement Plan

Windows for Elevation B & C\*\*

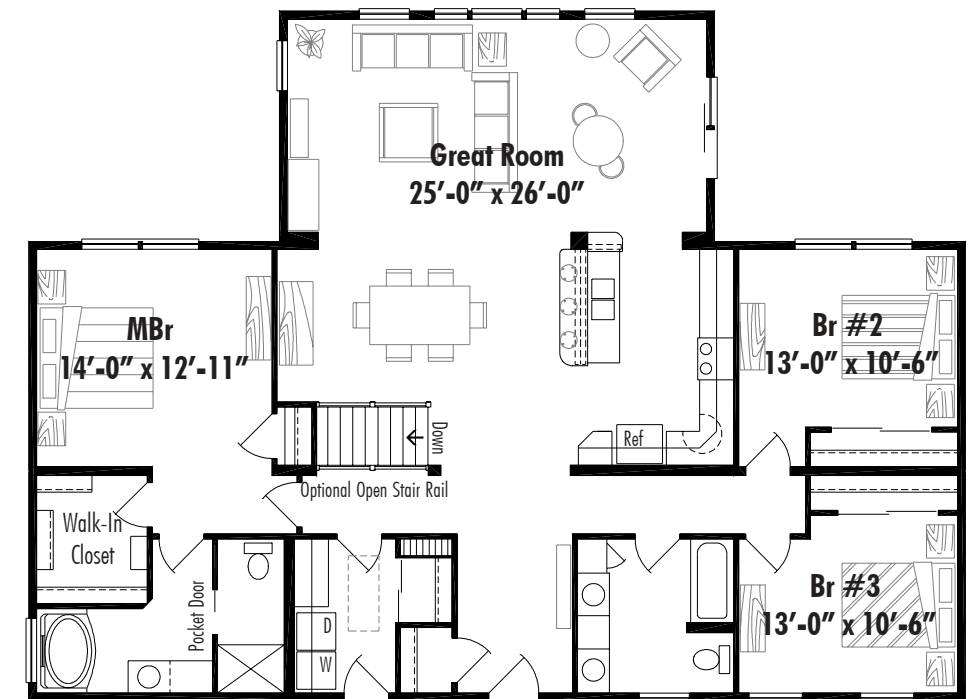
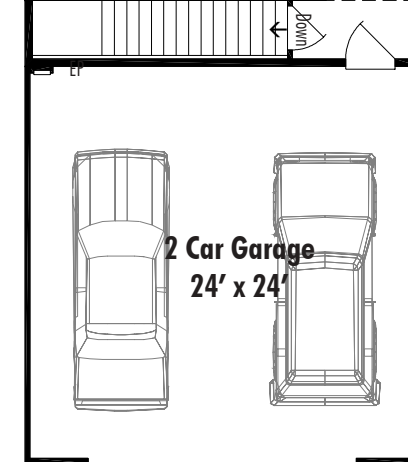

Windows for Elevation B & C\*\*

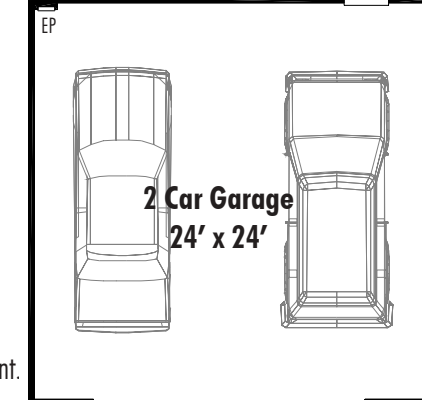

**Catawba Sunrise\***  
 1886 Sq. Ft. Living Area (Elev. A)  
 1900 Sq. Ft. Living Area (Elev. B & C)  
 Basement Plan

\* Floor Plans Reflect Elevation "A" Window Arrangement.  
 \*\*Elevation B & C adds 12" to Bedroom #3.  
 Fireplaces are Optional.